

# DRAINBOX

## 400-SQ 25-1,5

IMPIANTO DI ACCUMULO E SOLLEVAMENTO  
PER ACQUE REFLUE

La stazione di sollevamento è composta da un serbatoio in PE con all'interno un sistema di pompaggio completo di tubazione di mandata, con funzione di raccolta e rilancio ad una quota maggiore di acque piovane o reflue. Viene generalmente utilizzata a valle di scarichi domestici.

*The lift station consists of a PE tank with a pumping system inside, complete with delivery piping, with the function of collecting and releasing to a higher elevation rainwater or wastewater. It is generally used downstream of domestic drains.*

### Componenti

- Serbatoio in polietilene capacità 400 lt., coperchio non carrabile
- 1 elettropompa sommersa trifase
- 1 quadro elettrico trifase
- 1 galleggiante con 10 mt. di cavo
- 1 valvola di non ritorno a palla 2"½

### Components

- Polyethylene tank capacity 400 lt., non driveway cover
- 1 three-phase submersible electric pump
- 1 three-phase electrical panel
- 1 float switch with 10 m. cable
- 1 ball check valve 2"½

### Optional a richiesta / Optional on request:

- Kit prolunga 30 cm (per installare il serbatoio a una maggior profondità)
- Galleggiante 10 mt di cavo
- Kit segnalatore acustico/luminoso
- 30 cm extension kit (to install the tank at a greater depth)
- 10 m cable float
- Acoustic/lighting signaller kit

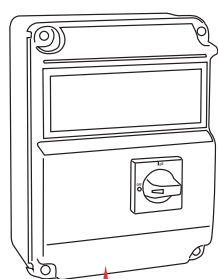
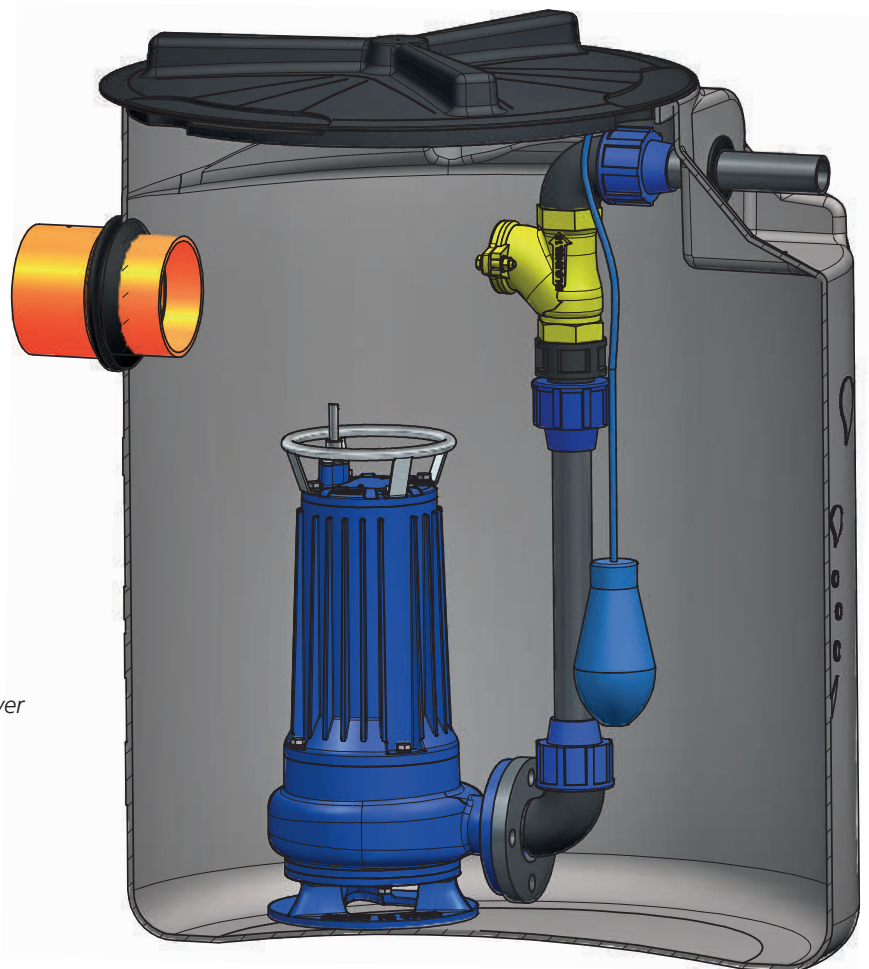

Quadro elettrico  
Electrical panel

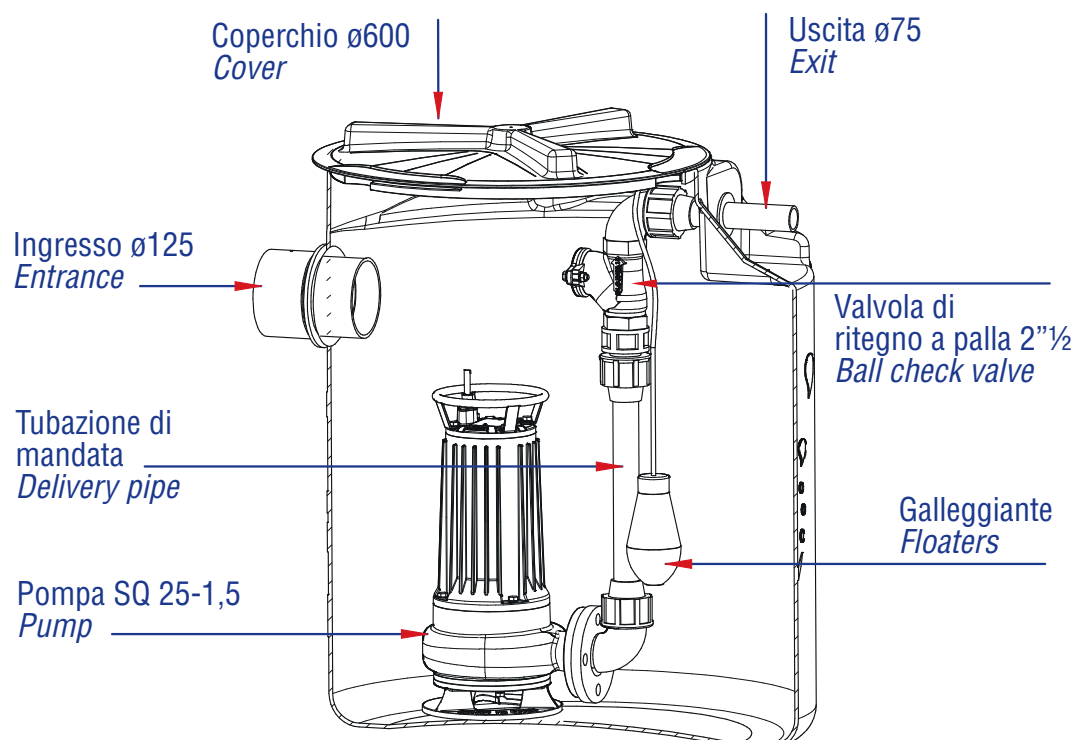

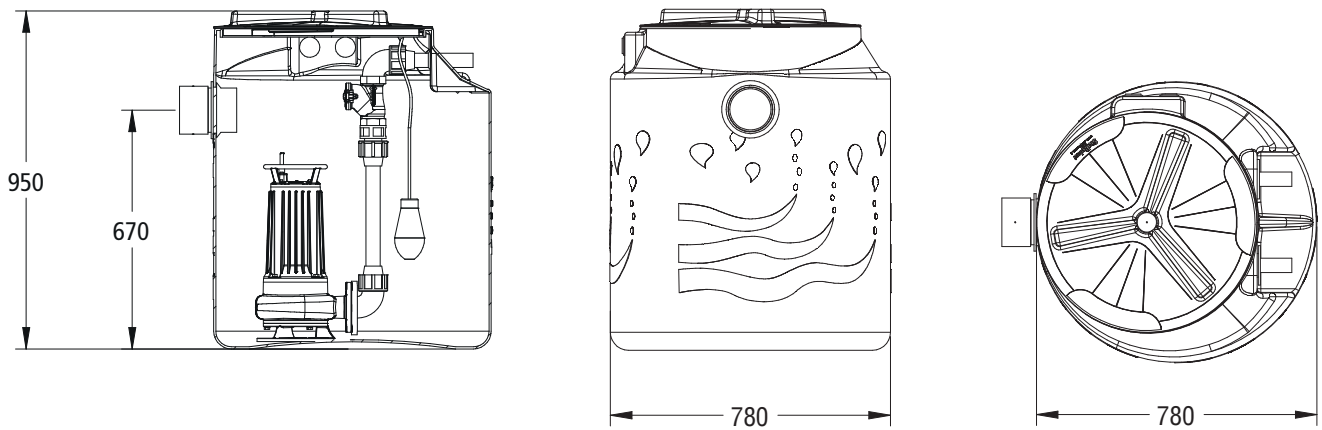

**Elettropompa sommersa per acque cariche / Submersible pump for dirty water**

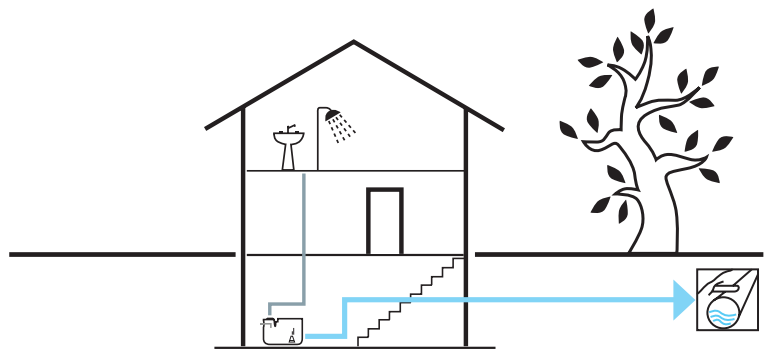
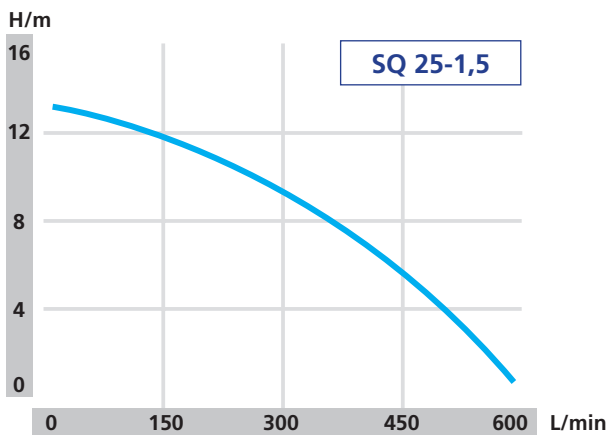

**Schema installazione / Installation diagram**

- Trifase 400V-50Hz
- Isolamento Classe F
- Protezione IP 68

- Corpo motore
- Corpo pompa
- Girante
- Albero motore
- Doppia tenuta meccanica in camera d'olio

- Ghisa
- Ghisa
- Ghisa
- Acciaio Inox AISI 304
- Ceramica/Grafite/NBR
- Silicio/Silicio/NB

- Three-phase 400V-50Hz
- Insulation Class F
- Protection IP 68

- Motor body
- Pump body
- Impeller
- Shaft with rotor
- Double mechanical seal in oil chamber

- Cast iron
- Cast iron
- Cast iron
- Stainless steel AISI 304
- Ceramic/Graphite/NBR
- Silicon/Silicon/NBR



TIPO - TYPE	SQ 25-1,5
P1	1750 W
Voltage	400 V
Frequency	50 Hz
Ampere	3,2 A
Q max.	600 l/1'
H max.	13 m
DNM	2"½